

RXC60B9 SERIES

High Voltage Contactors

600A CONTINUOUS DUTY

1000Vdc SYSTEM VOLTAGE

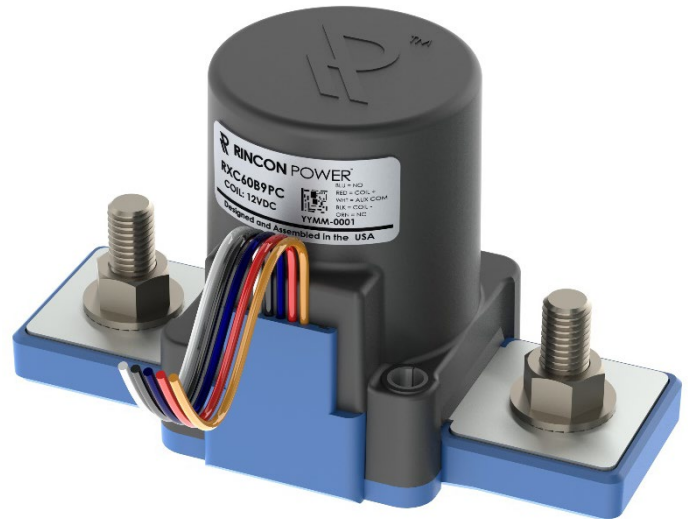

FEATURES

SPST Normally Open High Voltage Contactors

- Hermetic Ceramic Seal with gas fill for superior carry and switching performance
- Bi-Directional Power Switching
- Mechanically linked auxiliary contacts for accurate main position feedback
- Integrated coil economizer for optimized power consumption
- Integrated coil suppression with zero back EMF⁴
- Meets RoHS 2011/65/EU
- IEC60947-4-1 compliant



PERFORMANCE

TABLE 1. SPECIFICATIONS			
CHARACTERISTIC	MEASURE		
Contact Arrangement	Form X, SPST- NO		
Max Switching Voltage ²	1000 Vdc		
Dielectric Withstand Voltage (Leakage <1mA) Between Open Contacts	2200 VRMS (60 sec)		
	Between Contacts and Coil		
Mechanical Life	300,000 cycles		
Continuous Current (300mm ² conductor) ⁵	600A		
Overload Current	See Momentary Current Carry Graph		
Make and Break	See DC Power Switching graph		
Min Insulation Resistance	100 MΩ @ 1,000V (50 MΩ at end of life)		
Contact Resistance (Max) measured at 200A	0.3mΩ		
(Typical) measured at 200A	0.1-0.15mΩ		
Operate Time (Max, incl bounce)	25ms		
Release Time (Max)	10ms		
Shock - Functional, 1/2 Sine, 11ms	20 G Peak		
Shock - Destructive, 1/2 Sine, 11ms	50 G Peak		
Vibration, Sinusoidal (500-2000 Hz Peak)	15G		
Operating Temperature	-40°C to 85°C (170° Max Terminal Temperature)		
Sealed Contacts	Exceeds IP69K (Hermetically Sealed)		
Salt Fog	MIL-STD-810		
AUXILIARY CONTACTS	MEASURE		
Contact Arrangement	SPDT (Normally Open + Normally Closed)		
Continuous Current	3A / 24 VDC		
Minimum Current	10mA @ 5V		
ECONOMIZED DUAL COIL (20°C)	MEASURE		
Nominal Voltage	12V	24V	48V
Max Voltage	16V	32V	64V
Pick-up Voltage ³	≥9V	≥18V	≥36V
Drop-out Voltage	≤6V	≤12V	≤24
Inrush Current, Max (80 ms)	3.8A	1.9A	.9A
Coil Current	0.65A	0.33A	0.16A
Coil Power	7.8 W	7.8W	7.8W

Momentary Current Carry

600mcm (300mm² busbar)

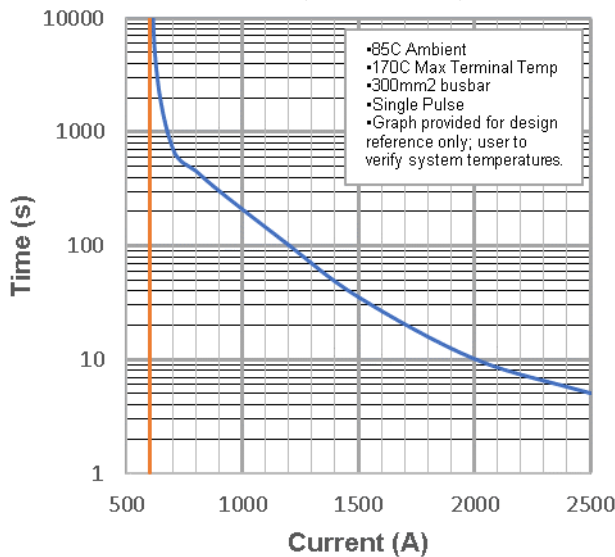

Estimated DC Power Switching Cycles

(Resistive Load)

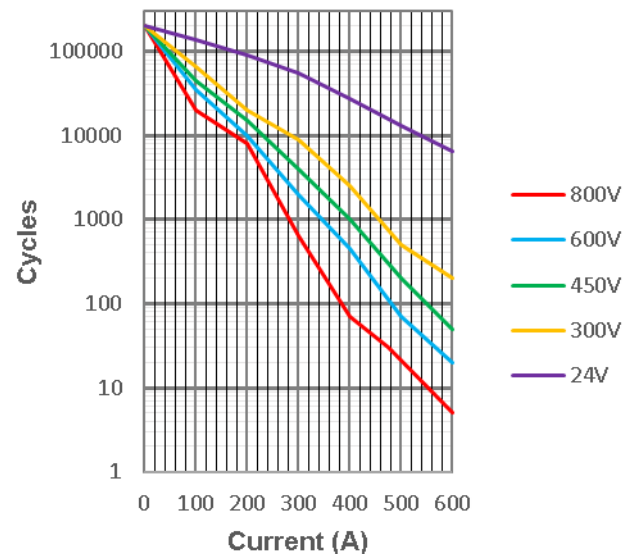

OPTIONS

TABLE 3. PRODUCT NOMENCLATURE

	CONTACT POLARITY	MOUNTING	COIL	AUXILIARY CONTACTS
RXC60	B Bi-directional	8 Chassis Mount, M12 Studs	P 12V dual (economized)	C SPDT, NO+NC
		9 Chassis Mount, M10 Studs (STANDARD)	Q 24V dual (economized) R 48V dual (economized)	X None

PRODUCT DIMENSIONS [mm]

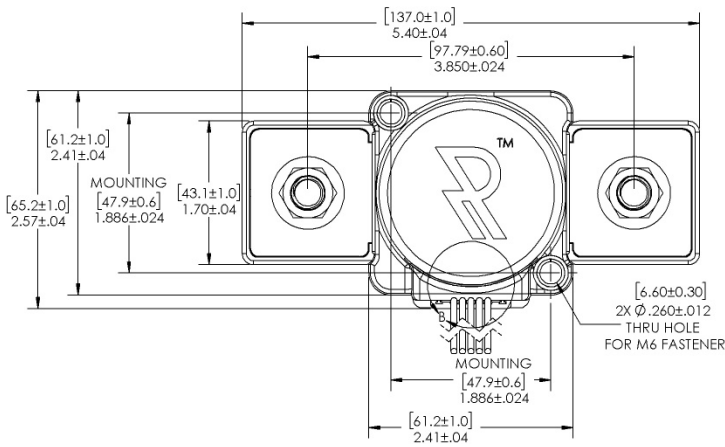
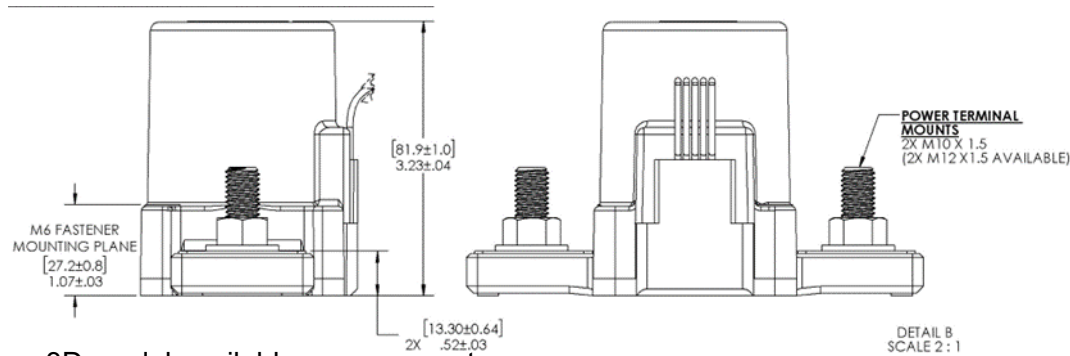
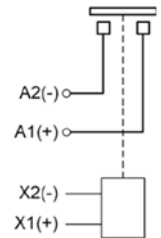

TABLE 4. DIMENSIONAL AND INSTALLATION

CHARACTERISTIC	MEASURE
Weight	1.8 lb, [830g]
Mounting Position	Any / Not Position Sensitive
Package Quantity	12 pcs
Install Torque, 2X M10 Main Terminals	125-150 in-lb, [14-17Nm]
Mounting Install Torque, 2X M6 Thru Hole	23-40 in-lb, [3-5Nm]
COIL / AUX WIRE	FUNCTION
Black	Coil GND (-)
Red	Coil POS (+)
White	Aux COM
Blue	Aux N.O.
Orange	Aux N.C.
Lead Wire Length	19 in +/- 1 in, [48 cm +/- 2.5 cm]
Lead Wire Size	20AWG, Stranded
Jacket Material	PVC
UL Ratings	UL 1007, UL 1569



Power Contacts



- 3D model available upon request

NOTES

1. Attach cables and busbars directly to the main terminal pad using the recommended install torque. Do not use washers or other materials between the contactor power terminals and the conductor.
2. Contactor may be used above Max Switching Voltage if the application does not require significant load breaking. Please contact Rincon Power for more details.
3. Dual coil economizer design: Pickup Voltage must be applied as a pulse. Do not ramp voltage.
4. Integrated coil suppression limits back EMF to 0V. External diodes or suppressors do not affect operation.
5. Rigid busbar structures have the potential to induce stress into the device and can damage the hermetic seal. When using busbars, it is important to design compliance into the bus bar structure via the use of flexible laminated busbars and or by means of incorporating adjustability in adjacent bolted interfaces.

Legal Disclaimer Notice for Rincon Power, LLC Datasheet

This legal disclaimer applies to purchasers and users of products manufactured by or on behalf of Rincon Power, LLC ("Rincon"). Unless otherwise expressly indicated in writing, Rincon's products, product specifications and data sheets relating thereto are subject to change without notice. Users should check for and obtain the latest revision information and verify that such information is current and complete before placing orders for Rincon's products. Users should always verify the actual performance of the Rincon's products in their specific systems and applications.

Except as expressly set forth in the relevant purchaser order terms and conditions or applicable agreement, Rincon makes no warranty, representation or guarantee regarding the products, expressed or implied, including, but not limited to, a warranty of merchantability or fitness for a particular purpose. To the maximum extent permitted by applicable law, Rincon disclaims (i) any and all liability arising out of the application or use of any product, (ii) any and all liability, including without limitation special, consequential or incidental damages, and (iii) any and all implied warranties, including warranties of fitness for particular purpose, non-infringement and merchantability.

In no event shall Rincon be liable for any incidental or consequential damages resulting from the use, misuse or inability to use the product. This exclusion applies regardless of whether such damages are sought based on breach of warranty, breach of contract, negligence, strict liability in tort, or any other legal theory.